

WALLYSKATER v2.1

INSTRUCTIONS

The WallySkater is used to:

- Measure for optimal anti-skate force
- Measure static frictional force of the tonearm that could impede playback and cantilever alignment in pivoted or linear tracking tonearms
- Measure inherent mechanical torque (bearings, wires, air supply tubes, etc.) in any tonearm - pivoted or linear - that could impede playback and cantilever alignment
- Visualize dynamic freedom of pivoted tonearm
- Ensure even stylus wear and reduce groove damage
- Reduce likelihood of mis-tracking by as much as 50%

1. WATCH THE WALLYSKATER INSTRUCTIONAL VIDEO SERIES ON THE WALLYTOOLS ANALOG SETUP TOOLS YOUTUBE CHANNEL (QR Code to the right). Go to the “Playlists” tab and watch the series in order. The visual aids will help you understand these written instructions.
2. Disengage the anti-skate mechanism completely
3. Make SURE the Vertical Tracking Force (VTF) is properly set
4. If you have a removable mat of any type (felt, cork, etc.) remove it while using the WallySkater
5. Familiarize yourself with the parts diagram on the last page of these instructions
6. Immobilize the platter with tape or a wedge to keep it from spinning



ASSEMBLY PROCEDURE

7. Place the WallySkater Base directly on the platter with the spindle located through the hole marked “Spindle”. Aim the line that runs through the center of the Base so it is pointed at the tonearm’s pivot point. See Figure 1
8. The peg at the bottom of the Post has been inserted at a very slight angle. For this reason, the lettering on the Post should face the tonearm once assembled.
9. Place one O-ring on the cylindrical Upper Beam and insert into the hole at the top of the vertical Post. Place a second O-ring onto the Upper Beam and secure it in place by pushing the two O-rings up against the Post. See Figure 2
10. Insert the Lower Beam into hole at the bottom of the Post. Use the two O-rings to secure Lower Beam on either side of the Post as in Figure 2. Rotate the Lower Beam in the hole so the markings are facing upwards.
11. Insert the post into one of the three “Outer Groove Area Mounts” according to your arm length. Round to nearest:
 - 11.1. 9” arms (~229mm) use the left-most hole
 - 11.2. 10.5” (~267mm) arms use the second hole
 - 11.3. 12” (~305mm) and greater arms use the third hole
12. Unwrap the plumb bob thread (blue string) and tonearm suspension thread (yellow string) from the Hanger until the strings hang from the slits at the bottom of the hole (Figure 3). *WallySkater Pro - unwrap strings until they hang from the hole.* Ensure the strings are not twisted.

13. Place the Hanger on the Upper Beam. Put an O-ring at the end of the Upper Beam to keep it from falling off. Adjust the plumb bob so that the tip of it is hovering just above – not touching – the top surface of the Lower Beam. Do NOT attach the yellow string to the tonearm yet.
 - 13.1. Basic WallySkater - Adjustments to length should be done with the thread pinched in the slit in the hanger directly underneath the hole for the Upper Beam. When adjusting length, ensure the thread is free from the locking slit. See Figure 3
 - 13.2. WallySkater Pro - Adjustments to string length are done by twisting the blue (plumb bob) and yellow (tonearm) thumb screws. Clockwise turn = shorten. Counterclockwise turn = lengthen.
14. If your tonearm has a horizontal damping mechanism, disable the damping function. If your damping function cannot be disabled, that is acceptable but you should expect the arm will respond more slowly and not swing as freely. This is generally nothing to be concerned about as long as the arm displays relatively free and consistent motion.

MEASURE TONEARM INTERNAL HORIZONTAL FORCES

15. THIS STEP SHOULD BE DONE BEFORE ALIGNING THE CANTILEVER TO CONFIRM THE ARM IS NOT GENERATING ANY HORIZONTAL FORCE ON THE CANTILEVER THAT WOULD CAUSE IT TO BE INCORRECTLY ALIGNED FOR PROPER OFFSET ANGLE
16. With the tonearm's cueing lever up and anti-skating mechanism completely disabled, move cartridge near the outer edge of the platter. Twist the Post in the Base so that the Lower Beam gets as close as possible to the front of the cartridge/headshell – but not touching it or the yellow string.
17. Place the yellow thread loop on the head shell finger-lift and adjust the length of the string so that the stylus hovers approximately 2-3mm above the platter when the cueing lever is lowered. The tonearm should be allowed to swing freely without the stylus touching the platter and without the tonearm touching the Lower Beam of the WallySkater.
 - 17.1. IF YOU DO NOT HAVE A FINGER LIFT
 - 17.1.1. Basic WallySkater: loosen one cartridge mounting screw and place the thread under the head of the screw
 - 17.1.2. WallySkater Pro: Unfurl the aluminum wire. Pass the wire just behind your cartridge and around the rear of the headshell or the armwand and form a loop that will pass through the yellow string loop. Twist the aluminum wire as you would a twist tie so that the wire and the string loop are now interlinked. Keep yellow string loop close to the armwand.
18. Slide the Hanger so that the stylus is located at the outside edge of the platter.
19. When looking at the lower beam with your eye at or just above Lower Beam height, note the number of hashmark lines between the plumb bob and the yellow string supporting the tonearm on the Lower Beam.
 - 19.1. Each hashmark line represents 1% of your VTF in horizontal force

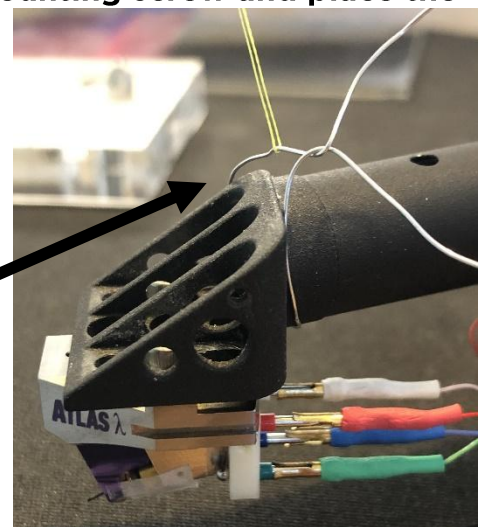

- 19.2. There should be no more than 3-4% with no anti-skating mechanism engaged. (Each hash mark on the lower horizontal bar of the WallySkater equals 1% of your VTF.) If you see more than this, contact us.
- 19.3. Gently tap on the headshell to cause the arm to swing and watch where it comes to rest. It should come to rest within $\pm 2\%$ of the last reading.
Damping mechanisms may cause slightly different results after each tap of the headshell. Take the average of 3-5 measurements.
- 20. Lift cueing lever to protect the cantilever while you carefully pull the Post out of its mount hole on the Base and move it into the "Inner Groove Area Mount".
- 21. Keep the aiming line in the Base pointed at the tonearm pivot and turn the vertical Post so that the Lower Beam is as close as possible to the cartridge/headshell without touching it or the yellow string.
- 22. Slide the Hanger so the stylus is near the inner groove area of the platter and take another reading. As above, you want no more than 3-4%. Again, gently tap on the headshell to cause it to swing slightly to ensure consistency.

DETERMINE MECHANICAL RESISTANCE OF THE TONEARM

23. Disengage the tonearm's anti-skating device completely

24. STATIC FRICTION (STICTION) TEST

- 24.1. With cartridge closer to the outer area of the platter, bring the tonearm to motionless state and note the "Starting Position" of the plumb bob relative to the yellow string. (This is the total horizontal force currently in play within your tonearm reviewed above in the MEASURE TONEARM INTERNAL HORIZONTAL FORCES step above.) This is your STARTING position for the stiction test.
- 24.2. While supporting the weight of your arm on a stable surface, SLOWLY move the Hanger from right to left (or left to right) while observing the distance between the plumb bob and the yellow string MINUS the Starting Position. The distance between the plumb bob and the yellow string noted at the moment when the tonearm responds to the horizontal force generated by the movement of the hanger by swinging in the direction of the plumb bob is the stiction of the tonearm. This resistance generated by tonearm wires, bearings, etc. should be no higher than 3-4 percent. Should the resistance measure higher than this, send video of the test to WAM Engineering for feedback.
 - 24.2.1. If your tonearm has viscous damping, expect the arm to take longer to respond to movements of the hanger. This is why it is important to move the hanger very slowly in order to get accurate results from the WallySkater.
- 24.3. Lift cueing lever and move the Post to the "Inner Groove Area Mount". Move cartridge to the inner area of the platter and re-do previous step.

MEASURE ANTI-SKATING FORCE

- 25. **NOTE:** adjustment of anti-skating force is always done AFTER adjusting stylus overhang and cantilever alignment but BEFORE azimuth optimization.
- 26. With the Post in the appropriate "Outer Groove Area Mount", the Hanger adjusted for the cartridge at the outer groove area and the Lower Beam moved as close as possible to the cartridge /headshell without touching it or the yellow string, lower the cueing lever and adjust the anti-skating device on the tonearm so that the distance between the plumb bob and the yellow string

is between 9-11 percent. 9" arms should approach 11% and 12" arms closer to 9%. (Again, each hash mark on the lower horizontal bar of the WallySkater equals one percent.) Lightly tap the headshell a couple times once the anti-skate has been set to confirm the arm returns to the same position.

27. Lift the cueing lever to protect the cantilever. Move the Post to the "Inner Groove Area Mount"
28. Slide the Hanger so the cartridge is at the inner playing region of the platter
29. Move the Lower Beam is as close as possible to the cartridge/headshell without touching it or the yellow string. Lower the cueing lever and take another readout of the distance between the plumb bob and the string supporting the tonearm. Lightly tap the headshell a couple times to confirm it returns to the same position. Lift cueing lever.
 - 29.1. The anti-skating force at the Inner and Outer positions may vary. If you find a large discrepancy of values between the two (+-4%), contact WAM Engineering to discuss. When variations between outer and inner occur, set the anti-skate mechanism so that the average of the outer and inner results is your tonearm's target value
30. Note and record the setting on the anti-skate mechanism

LINEAR BEARING AND PIVOTED LINEAR TRACKING TONEARM NOTE

The WallySkater should be used on all linear pivoted tracking and linear bearing tonearms to ensure the arm is not being influenced by horizontal forces such as torqued tonearm wiring, out-of-level bearing or other factors. Static friction test should also be performed on all linear pivoted tracking and linear bearing arms.

IMPORTANT: For tonearms with true linear bearings (e.g., Eminent Technology ET2, Kuzma Air Line, Clearaudio TT-2 etc.) place the Post in the "Linear Bearing Tonearm Test Mount" hole for all tests across the record. For pivoted linear tracking tonearms you will need to move the Post during testing as per instructions above for standard pivoted 9" tonearms.

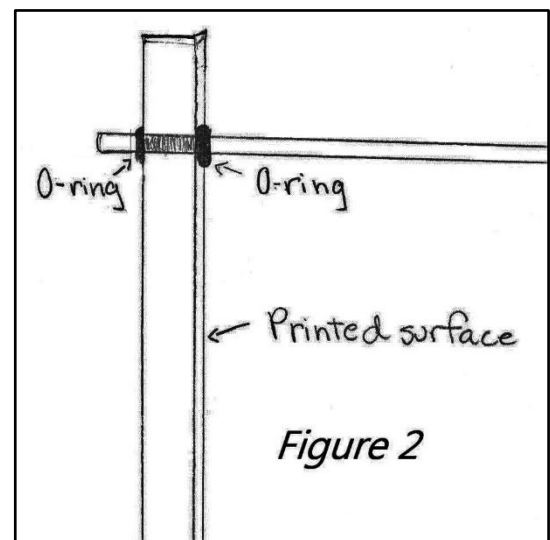
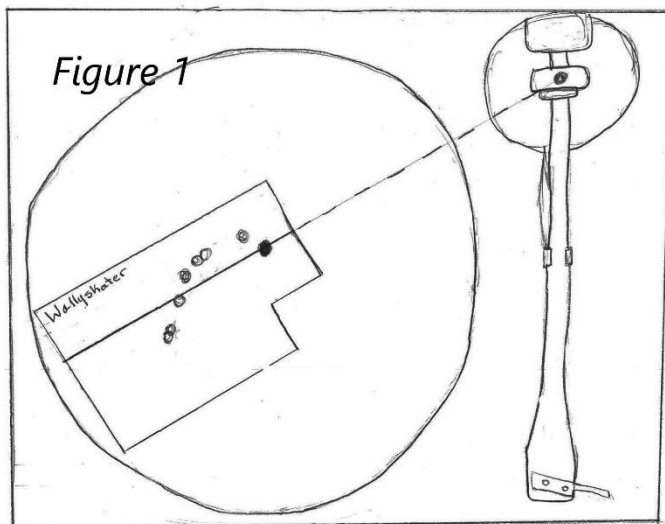

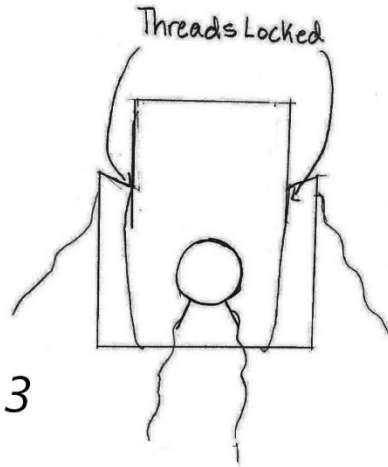
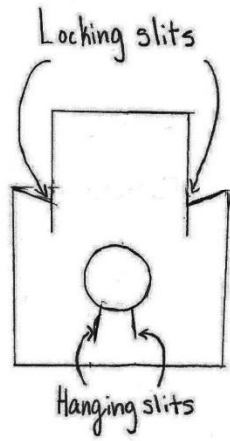
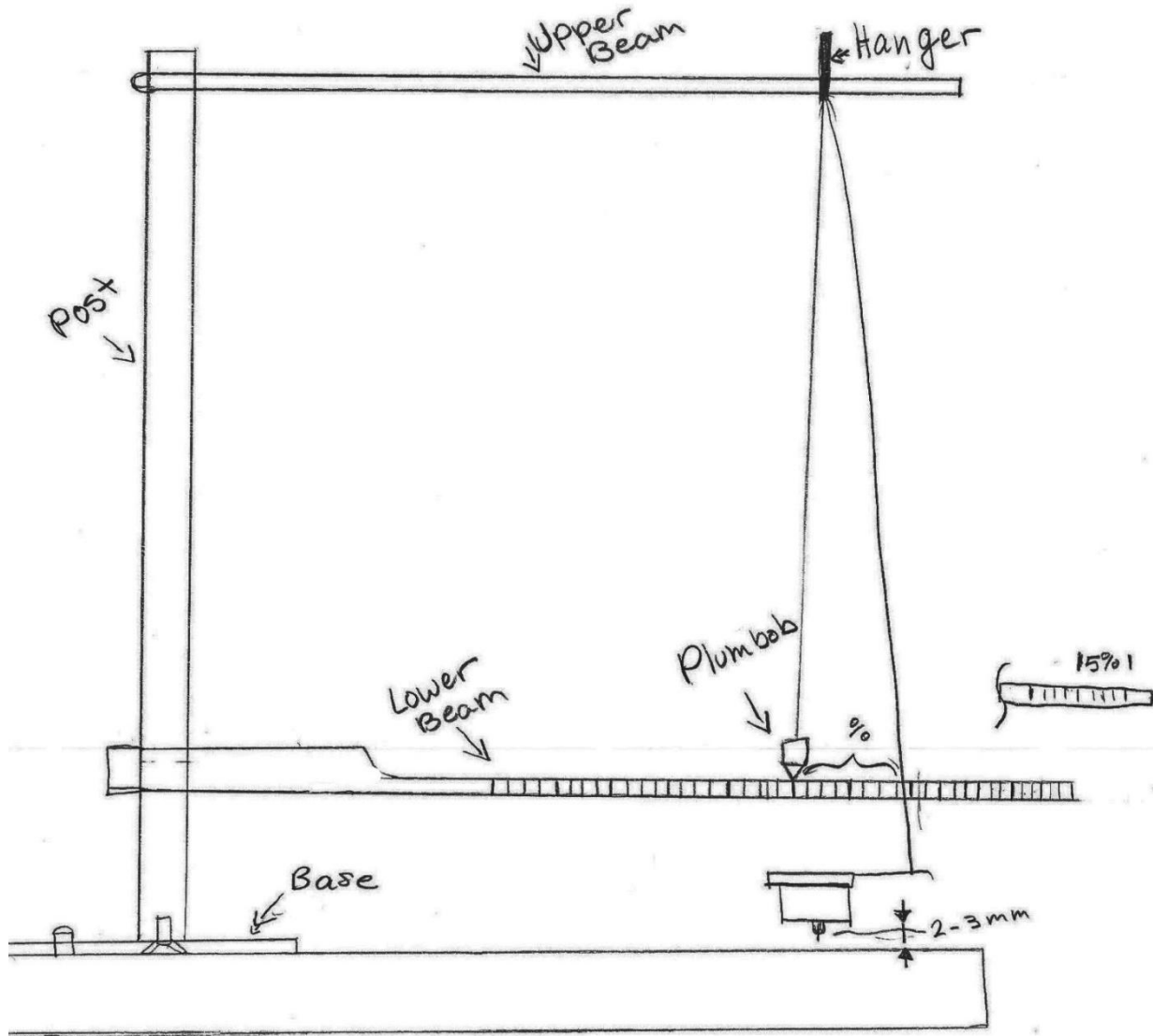

Figure 3



ENJOY ANALOG FOREVER!!! - *Wally Malewicz*

wallyanalog.com / wallyanalogtools@gmail.com